



Hochschule Karlsruhe
Technik und Wirtschaft
UNIVERSITY OF APPLIED SCIENCES



Hochschule Karlsruhe
Technik und Wirtschaft
UNIVERSITY OF APPLIED SCIENCES

Prof. Dr. Klemens Gintner
klemens.gintner@hs-karlsruhe.de





Location





Hochschule Karlsruhe
Technik und Wirtschaft
UNIVERSITY OF APPLIED SCIENCES



About 8200 students
About 180 professors



HsKA – a green campus in a green city ...

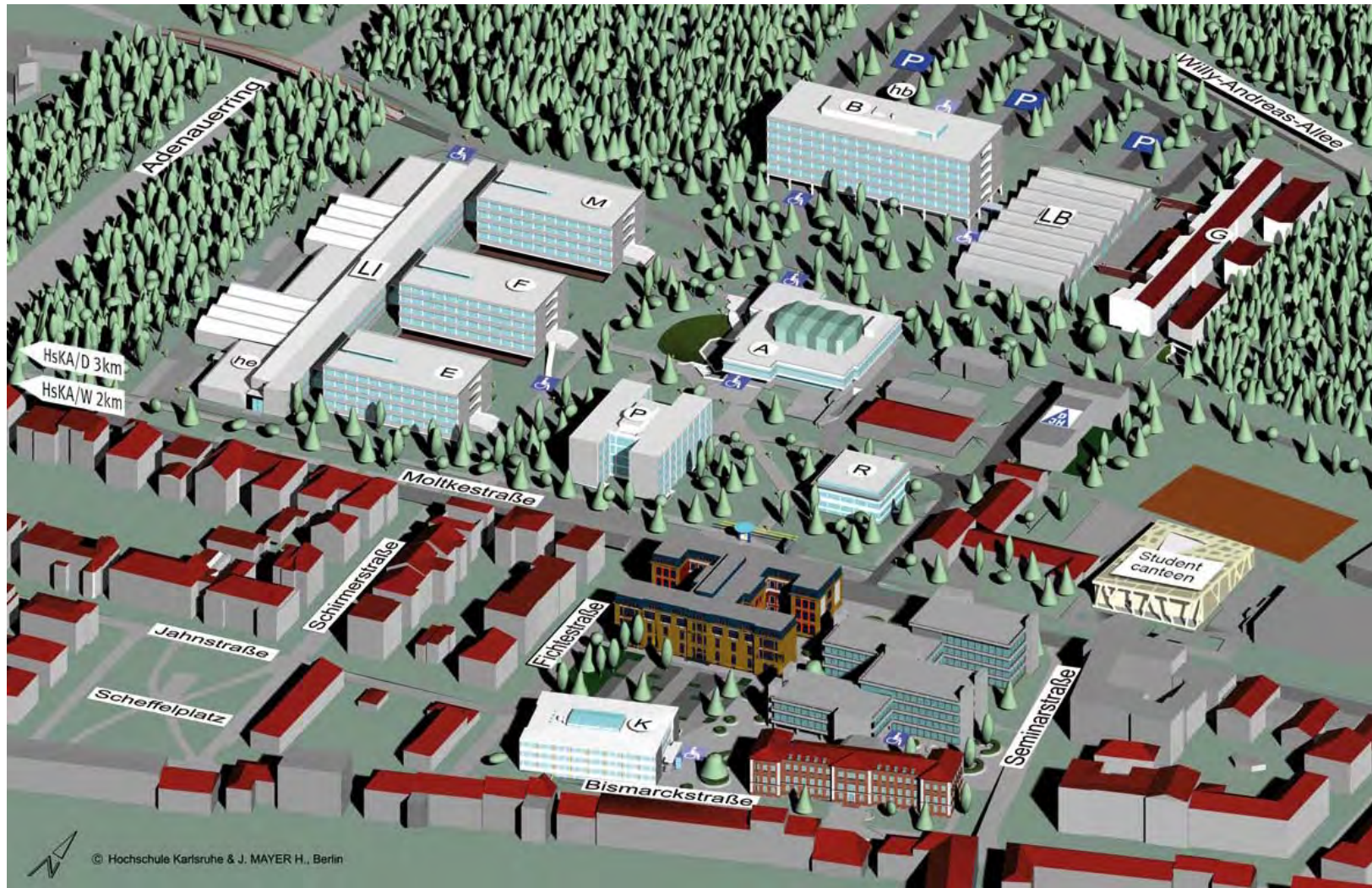



- **Six faculties at HsKA:**
 - ✓ Architecture & Construction Engineering
 - ✓ Computer Science & Business Information Systems
 - ✓ Electrical Engineering & Information Technology
 - ✓ Information Management & Media
 - ✓ Management Science & Engineering
 - ✓ Mechanical Engineering & Mechatronics
- **Number of degree programs:**
 - ✓ 20 Bachelor's programs
 - ✓ 18 Master's programs



Study Courses at the Faculty MMT - Engineering -

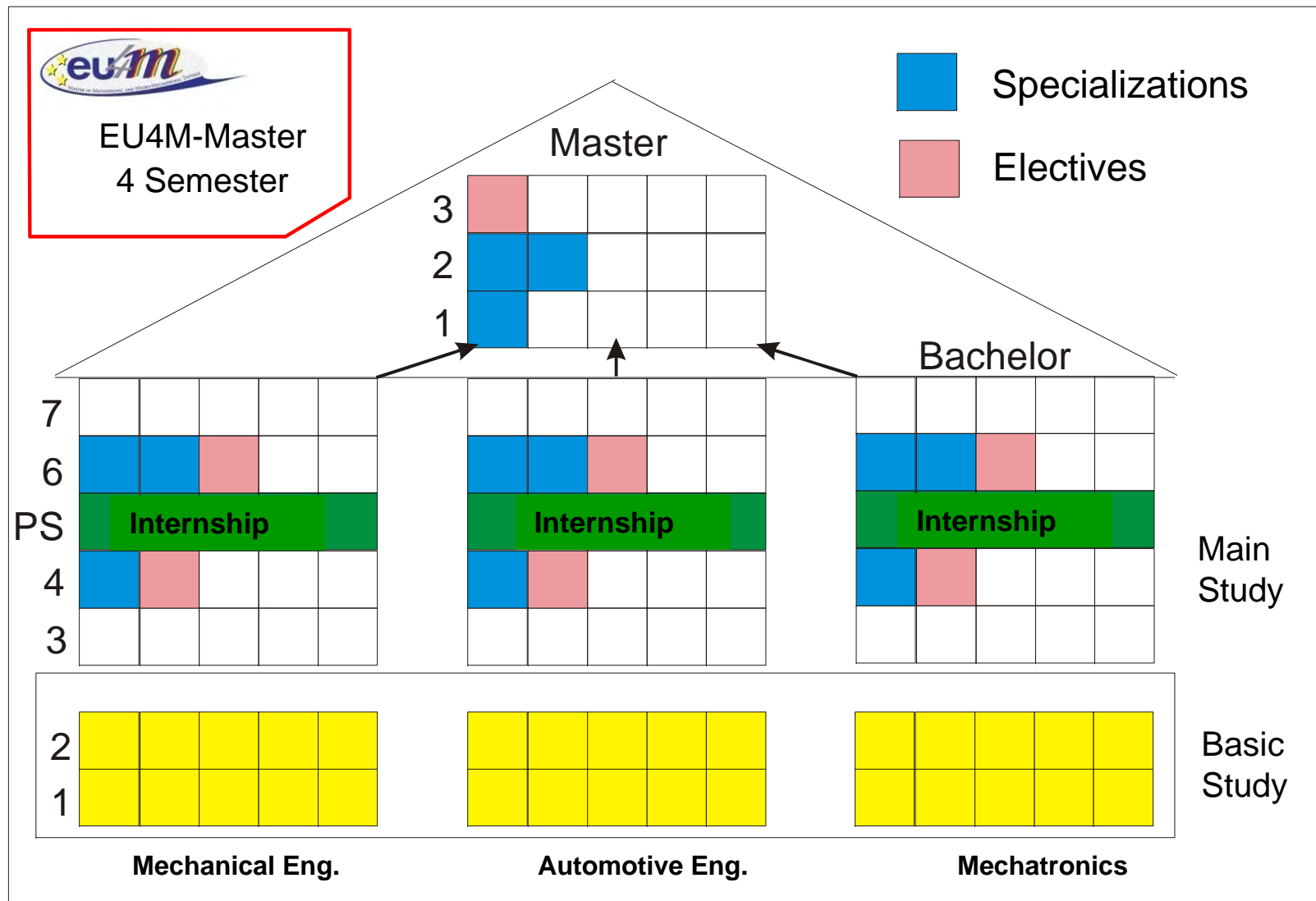



Ranking 2014

**Wirtschafts
Woche**

Handelsblatt

Fachhochschulen				
Wirtschaftsingenieurwesen	Informatik	Wirtschaftsinformatik	Elektrotechnik	Maschinenbau
1. Reutlingen	1. München	1. Karlsruhe (HsKA)	1. Aachen	1. Berlin (HTW)
2. Karlsruhe (HsKA)	2. Berlin (HTW)	2. Berlin (HTW)	2. München	2. Esslingen
3. München	3. Dresden (HTW)	3. Pforzheim	3. Karlsruhe (HsKA)	2. Mannheim
4. Pforzheim	4. Furtwangen	4. Reutlingen	4. Pforzheim	4. Pforzheim
5. Berlin (HTW)	5. Darmstadt	5. Bonn-Rhein-Sieg	5. Köln	5. Reutlingen
6. Darmstadt	6. Karlsruhe (HsKA)	6. Köln	6. Esslingen	6. Aachen
6. Esslingen	6. Dortmund	7. München	7. Leipzig (HTWK)	7. Berlin (BHFT)
8. Mannheim	8. Aachen	8. Berlin (HWR)	7. Kaiserslautern	8. Karlsruhe (HsKA)
8. Dresden (HTW)	8. Köln	8. Dresden (HTW)	9. Dortmund	8. Köln
10. Heilbronn	8. Mannheim	10. Furtwangen	9. Dresden (HTW)	8. Leipzig (HTWK)
			9. Hamburg (HAW)	8. Darmstadt
			9. Mannheim	8. Hamburg (HAW)

Universities evaluated by HR managers of German companies: Karlsruhe University of Applied Sciences was awarded first, second and third places for their degree programs in the current university ranking of the WirtschaftsWoche magazine

The ranking deliberately concentrates on the practical relevance of degree programs.

571 HR managers of small and medium-sized businesses, as well as of large enterprises, participated in the current survey carried out between January and April 2014. The survey focused on economic subjects such as business administration, industrial engineering, mechanical engineering, electrical engineering, computer science, and business information systems



Faculty of Architecture and Construction Engineering

Bachelor Programs

- **Architecture**
- **Civil Engineering**
- **Construction Management and Economics**
- **Tri-national Civil Engineering (French/German)**

Master Programs

- **Architecture**
- **Civil Engineering**
- **Construction Management and Economics**
- **Tri-national Civil Engineering (French/German)**





Faculty of Computer Science and Business Information Systems

Bachelor Programs

- **Business Information Systems**
- **Computer Science**

Master Programs

- **Business Information Systems**
- **Computer Science**

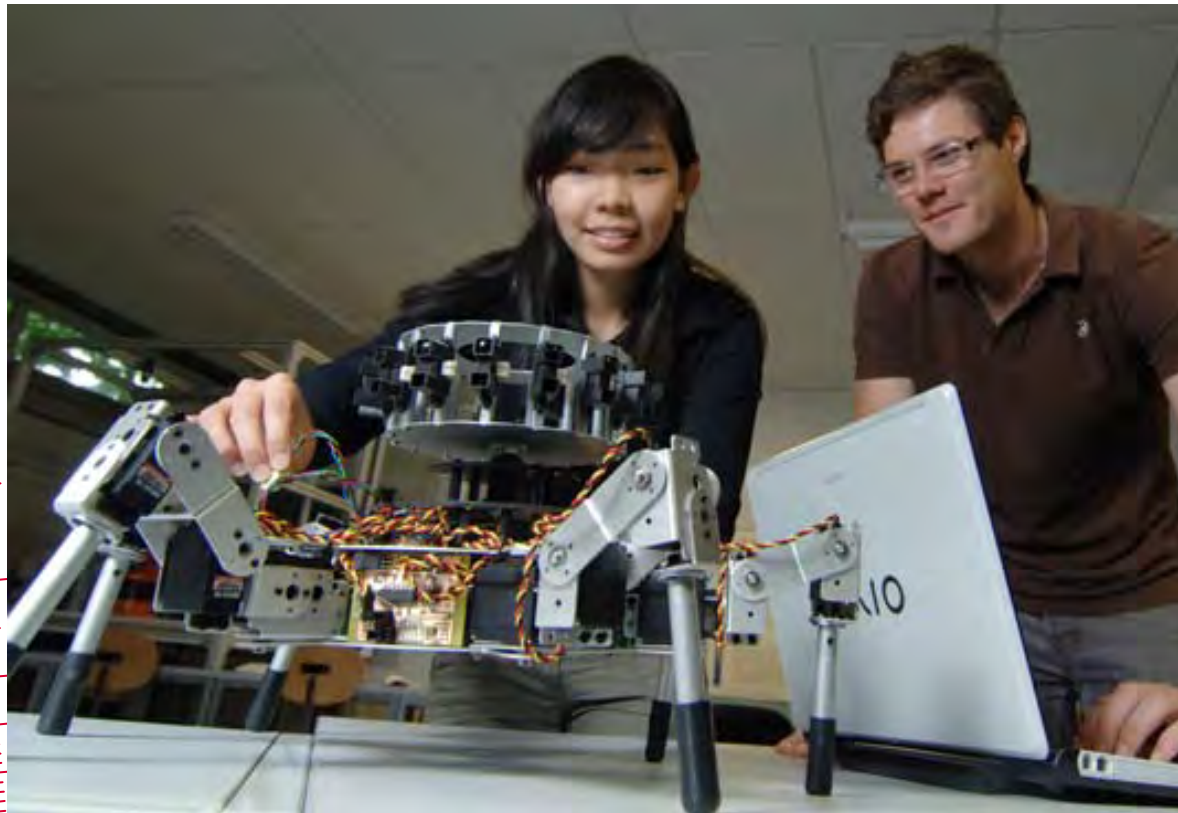



Faculty of Electrical Engineering and Information Technology

Bachelor Programs

- **Communications Engineering and Information Technology**
- **Energy and Automation Technology**
- **Sensorics**

Master Programs

- **Electrical Engineering**
- **Sensor Systems Technology**
- **Sensor Systems Technology (English)**

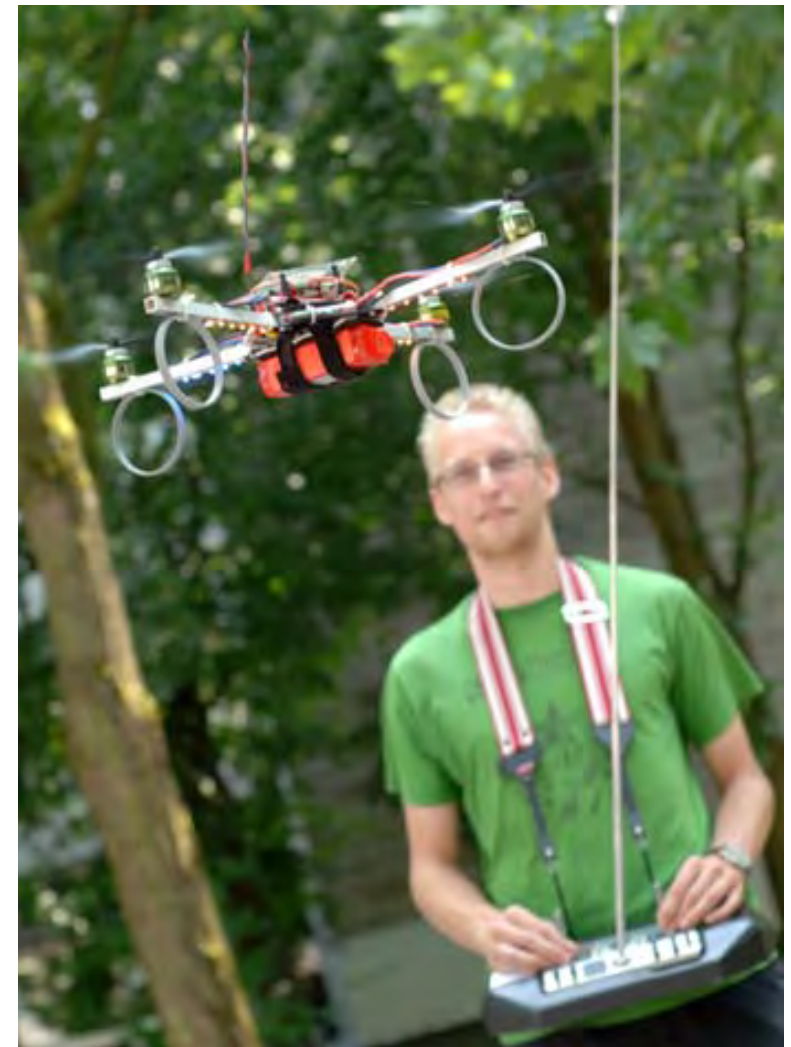



Bachelor Programs

- **Transport Management**
- **Geodesy and Navigation**
- **Communication and Media Management**
- **Geo-Information Management**
- **Culture, Media and Technologies**

Master Programs

- **Transport Systems**
- **Communication and Media Management**
- **Geomatics**
- **Geomatics (English/German)**

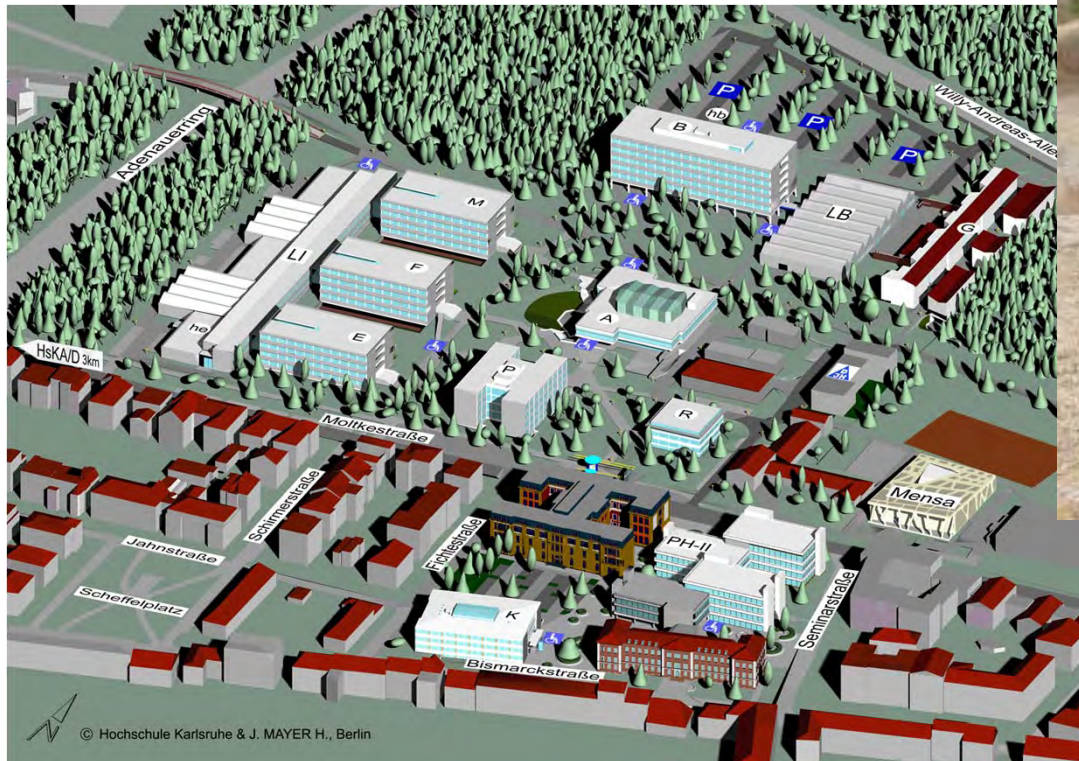



Faculty of Management and Engineering

Bachelor Programs

- **Business Administration and Engineering**
- **International Management**
- **Technical Communication**

Master Programs

- **Business Administration and Engineering**
- **International Management**
- **Sales Engineering**
- **Technical Communication**





Faculty of Mechanical Engineering and Mechatronics

Bachelor Programs

- **Automotive Engineering**
- **Mechanical Engineering**
- **Mechatronics**

Master Programs

- **Mechanical Engineering**
- **Mechatronics**
- **Energy Efficient Mobility**
- **Mechatronic and Micro-Mechatronic Systems**

(German/Spanish or German/French)

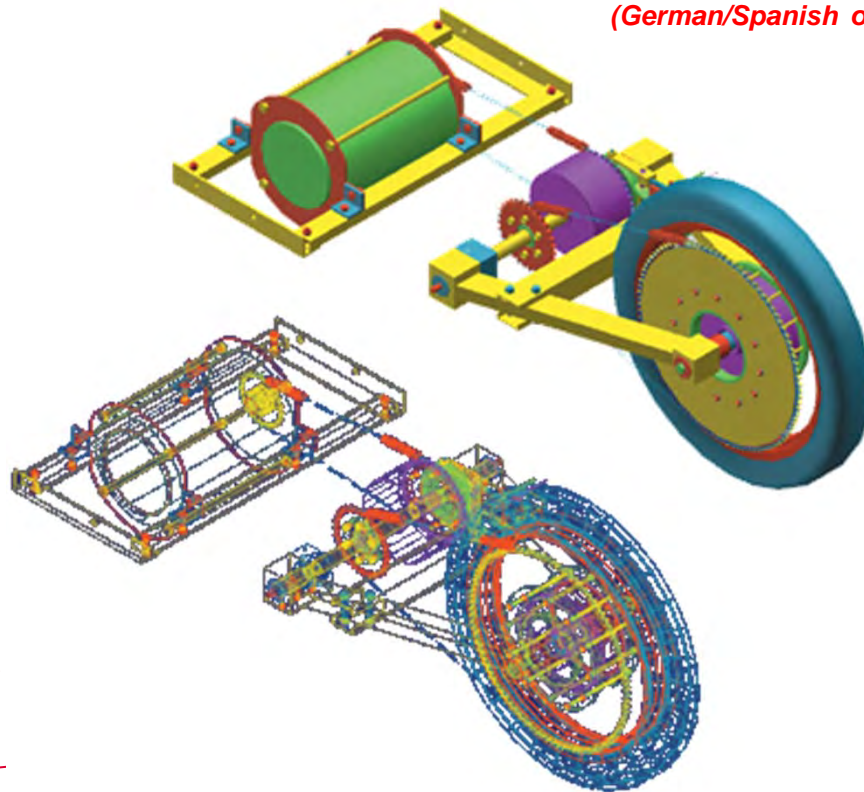



Research Institutes at HsKA

- Applied computer science and geoinformatics
- Intelligent measurement systems and sensor technologies
- Construction, environmental, and process technology
- Institute of Materials and Processes



Research Institutes at HsKA - Faculties

- [Institut für Geomatik IfG](#) (Institute of Geomatics) is located at the Faculty of Information Management and Media,
- [Versuchsanstalt für Wasserbau VAW](#) (Research Institute of Hydraulic Engineering) is located at the Faculty of Architecture and Construction Engineering,
- Labor für Automatisierungstechnik LAT (Laboratory for Automation Technology) is managed jointly by the Faculty of Electrical Engineering and Information Technology, and the Faculty of Computer Science and Business Information Systems,



Research Institutes at HsKA

- Institut für Energieeffiziente Mobilität IEEM (Institute of Energy Efficient Mobility) is located at Faculty of Mechanical Engineering and Mechatronics
- Institut für Kälte-, Klima- und Umwelttechnik IKKU (Institute of Refrigeration, Air-Conditioning, and Environmental Engineering) a joint institute of all faculties.
- [Australian-German Study Centre for Optofluidics and Nanophotonics \(SCON\)](#) is a joint project between [RMIT University](#) in Melbourne, Australia and HsKA. The goal is to attract students to research work and state-of-the-art technologies.



Cooperation with Industry

Technology Transfer Centers for

- Aerospace Engineering
- Biomedical Engineering
- Energy Efficient Mobility
- Electrical Power Supply and Electromagnetic Compatibility
- Energy Efficiency in Process Engineering
- Opto-electronic and Sensor Technology
- Energy Efficient Mobility
- Technical Consultation



An International University

- International degree students: 12%
- Student exchanges per year: approx. 100
- 110 International partner universities in 40 countries
- 9 international study programs, e.g.
 - ✓ Trinational Bachelor & Master in Civil Engineering (University of Applied Sciences Northwestern Switzerland & Université de Strasbourg, France)
 - ✓ Master in Electrical Engineering (Ryerson University, Canada)
 - ✓ Master in Mechanical Eng. / Automotive Eng. / Mechatronics (ENSMM de Besançon, France)
 - ✓ Master in Sensor Systems Technology (VIT University, India)
 - ✓ ERASMUS Mundus Master in Mechatronic and Micro-Mechatronic Systems (Universidad de Oviedo, Spain & ENSMM de Besançon, France)



Formula Student Combustion (FSC)





Formula Student

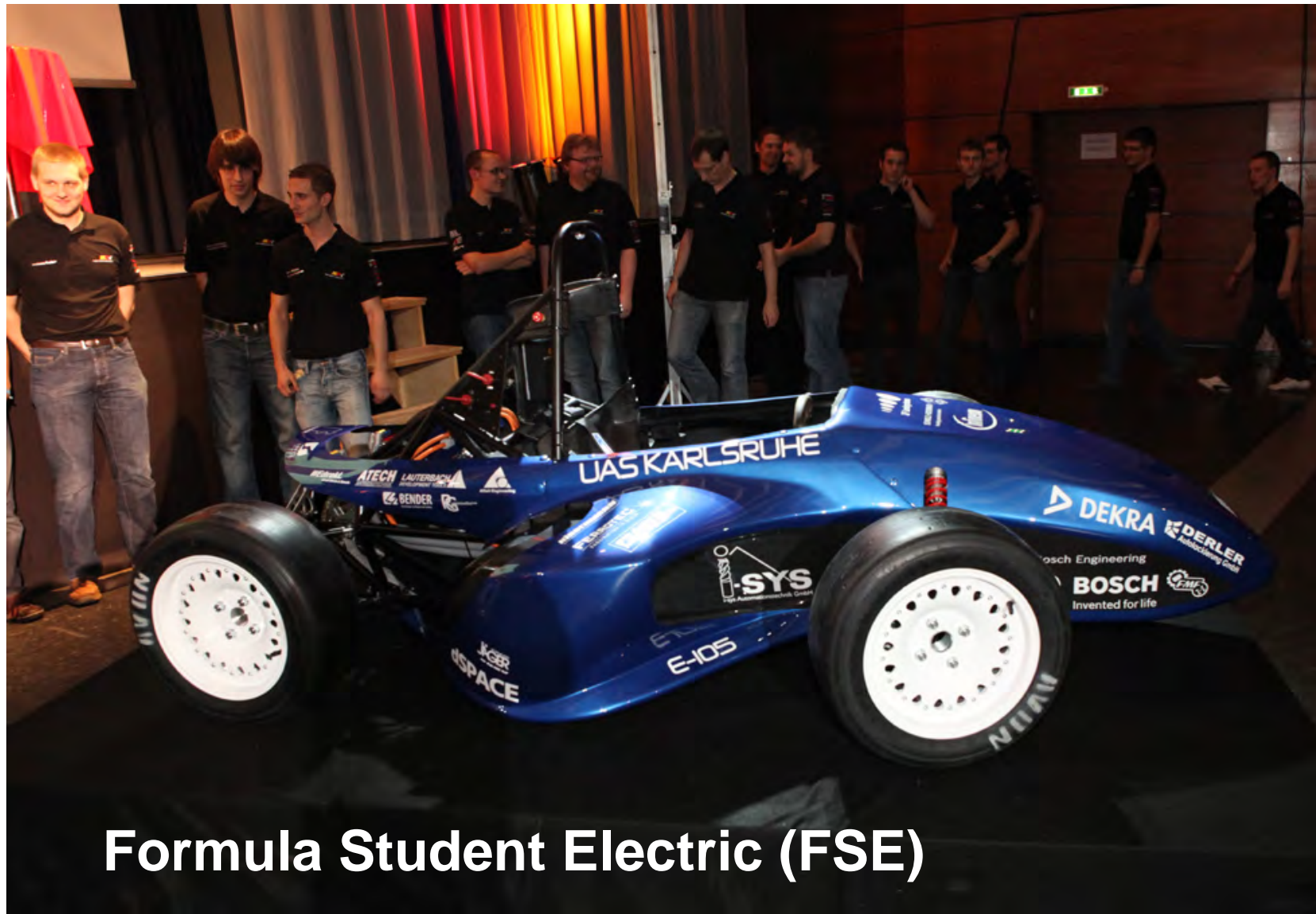



International Program at HsKA (Winter- and Summer Semester)

- Fundamentals of Corporate Management (IP 201, 3 ECTS cp)
- Innovation Management for Technical Products (2 ECTS cp)
- Intercultural Communication (IB 641, 2 ECTS cp)
- High Performance Materials (MB 622, 3 ECTS cp)
- Design Exercises 2 (MB 412, 4 ECTS cp)
- Sensors + Laboratory (FTB 731, 2 ECTS cp + 1 ECTS cp)
- Magnetic Sensors (IP 410, 4 ECTS cp)
- Engineering Design I (6 ECTS cp)
- Reliability Engineering (IP 402, 5 ECTS cp)
- Generation and Storage of Renewable Energies (IP 403, 3 ECTS cp)
- Global Financial Markets (IP 905, 5 ECTS cp)
- International Project Management (IP 204, 3 ECTS cp)
- Accessing the German Labor Market (IP 902, 3 ECTS cp)
- Presentation Techniques (S 9956, 2 ECTS)



International Relations – Partner Universities

- École Nationale Supérieure de Mécanique et des Microtechniques (ENSMM) Besançon/France (Dual Master Degree)
- UTBM Université de Technologie de Belfort-Montbéliard /France
- California Polytechnic State University (CalPoly) in San Luis Obispo, California, USA (Dual Master Degree),
- Minnesota State University Mankato (USA)
- Glasgow Caledonian University, Scotland (GB)
- Universidad de Oviedo (E.T.S. de Ingenieros Industriales) in Gijon/Spain,
- Universidad Politécnica de Valencia (UPV) in Valencia/Spain,
- Ryerson University Toronto/Canada, University of Waterloo/Canada
- Università degli studi di Parma/Italy
- Tecnológico (TEC) Monterrey/Mexico
- CEFET(Centro Federal de Educação Tecnológica) Minas Gerais, Belo Horizonte/Brazil



Hochschule Karlsruhe
Technik und Wirtschaft

UNIVERSITÄT



Ryerson University



UNIVERSIDAD
POLITECNICA
DE VALENCIA



Some of our

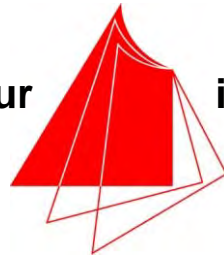

international partners



Universitatea "Politehnica"
din Timisoara





Faculty MMT: Bachelor: Mechatronics

Basic study period:

- Mathematics
- Engineering Mechanics, Materials
- Electronics, Computer Engineering, μ C
- Design, Manufacturing, CAD
- Simulation Tools: Pro Engineer (CAD), LTSPICE, MATLAB

Main study period:

- Control Systems
- Sensors & Actuators
- Automation (Hardware, Software - HMI)
- Projects
- Bachelor-Thesis
- Electives:
 - Micro-Systems (-> packaging)
 - Mechatronics in Mechanical Eng.
 - Aeronautical Eng.
 - Refrigeration & Air Conditioning





Faculty MMT: Bachelor: Automotive Engineering

Automobile as a **mechatronic system!**

Basic study period:

- Mathematics
- Mechanics, Materials Science
- Electronics, Computer Science, μC
- Design, Production
- Basics automobile technology

Main study period:

- Numerical Mechanics
- Automobile technology
- Control Systems, Signal processing
- Actuators & Sensors
- Projects
- Bachelor-Thesis
- Electives:
 - Automotive Systems (E.E.)
 - Drivetrain (M.E.)

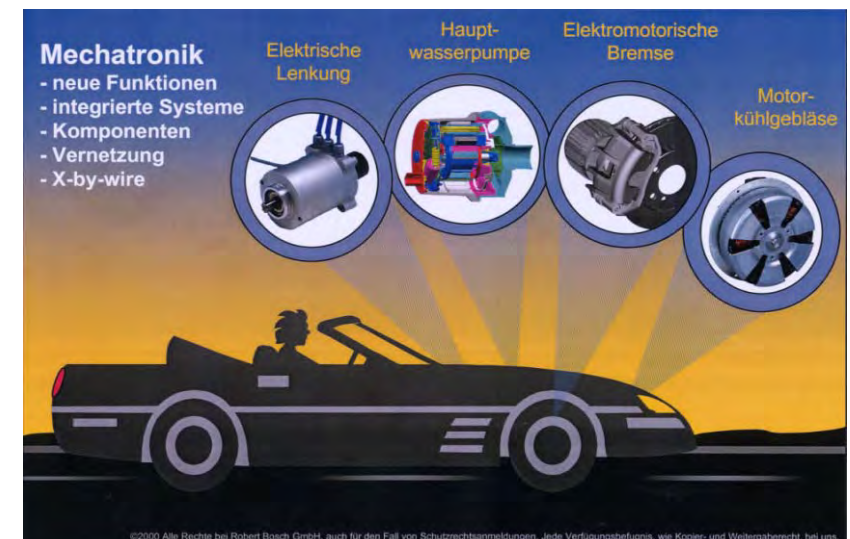
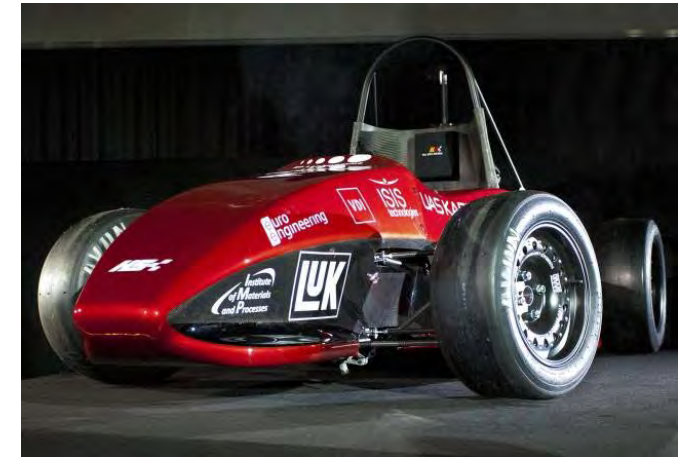

Mechatronic applications in the automobile
WiWo 17, 2006



Faculty MMT: Bachelor: Mechanical Engineering

Basic study period:

- Mathematics
- Mechanics, Materials Science
- Thermodynamic
- Design and Production Engineering

Main study period:

- Fluid Dynamics
- High Performance Materials
- Project
- Bachelor-Thesis
- Electives:
 - Refrigeration & Air Conditioning
 - Design
 - Production Engineering
 - Automotive Engineering (Power Train)
 - Aeronautical Engineering





Faculty MMT: Master Programs

Master Program – Graduate Level:

- Mechatronics
 - Micro-Mechatronic Systems

- Automotive Engineering
 - Propulsion Systems
 - EE-Systems

- Mechanical Engineering
 - Computer-aided Product- and Process-Development
 - HVAC

- EU4M: Mechatronic and Micro- Mechatronic Systems
 - ENSMM Besancon (France) and
 - University Oviedo (Spain)



Automotive Technology: Impressions



<http://www.highspeed-karlsruhe.de/> F102

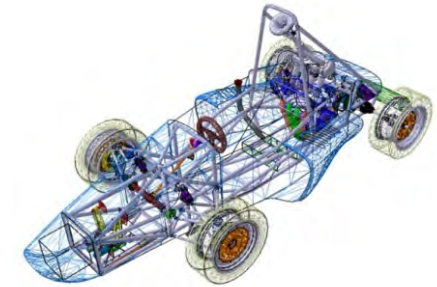

Dynamometer



CAN-Bus Demo



Wind Tunnel



Engine Test Bench

HAWtech Summer School 2015





Hochschule Karlsruhe
Technik und Wirtschaft
UNIVERSITY OF APPLIED SCIENCES

HAWtech German Alliance for
Applied Sciences

Objectives of the HAWtech Summer School 2015 Automotive Engineering:

- Intensification of the cooperation with partner Universities
- Unique opportunity to get to know new trends
in automotive engineering
- Contact to the leading companies that are working
in these fields (Bosch, fsd, IPG,)



Hochschule Karlsruhe
Technik und Wirtschaft

UNIVERSITY OF APPLIED SCIENCES

Application & further information

Time schedule:

- Karlsruhe: 18th July - 24th July 2015
- Dresden: 25th July - 29th July 2015
- Berlin: 30th July - 01st August 2015

4 ECTS credit points will be awarded.

Costs:

- Incl. tuition fee, accommodation and transfer (Karlsruhe → Dresden → Berlin)
- Approx. 750€

Application & Further Information:

- www.hs-karlsruhe.de/fk-mmt/hawtech
- www.hs-karlsruhe.de/hawtech_application
- www.htw-dresden.de/index/forschung/hawtech-summer-school

Please send your application to automotive@hs-karlsruhe.de

Contact:

Karlsruhe University of Applied Sciences (HsKA)

Prof. Dr. Peter Neugebauer

Moltkestraße 30, D-76133 Karlsruhe, Germany

Phone: +49 (0) 721 925 1421

Peter.Neugebauer@hs-karlsruhe.de



Hochschule Karlsruhe
Technik und Wirtschaft
UNIVERSITY OF APPLIED SCIENCES

Berlin University of Applied Sciences (HTW Berlin)

Prof. Dr. Michael Lindemann

Wilhelminenstraße 75A, D-12459 Berlin, Germany

Phone: +49 (0) 30 5019 4221

Michael.Lindemann@htw-berlin.de



Hochschule für Technik
und Wirtschaft Berlin
University of Applied Sciences

HAWtech

German Alliance for
Applied Sciences

HAWtech

Summer School 2015

Automotive Engineering

18th July - 01st August 2015

An outstanding opportunity
for Bachelor students to get to know the
automotive engineering capabilities
in Germany and to gain
additional ECTS credit points



Sat 18th - Fri 24th July 2015
Karlsruhe



Located in the German south-west, in the Rhine valley near the border with France, Karlsruhe is the center of one of the country's premier technology regions. Nine institutions of higher education with a combined student population of over 42,000 make Karlsruhe a genuine student place, with the majority of students enrolled in engineering and IT disciplines. An interesting engineering programme is offered in the Summer School in Karlsruhe.

The programme* is planned to be:

- Power supply diagnostics
- Hands-on laboratory: CAN-bus
- CarMaker Workshop
- Job Interview training
- Porsche- or Daimler-Museum Stuttgart

Sat 25th - Wed 29th July 2015
Dresden



Dresden is the capital of the federal state of Saxony and also known as "Silicon Saxony" with companies such as Infineon and GLOBALFOUNDRIES. The centre of the city is said to be the "Florence on the river Elbe"; it has a long history as the capital and royal residence for the Kings of Saxony.

Different production techniques and research on traffic accidents are important topics of the Summer School in Dresden:

The programme* in Dresden is planned to be:

- Introduction to Matlab/Simulink and Code Generation
- Development of Driver Assistance Systems using Simulink
- Visiting accident research institute and fsd technology center (periodical technical inspection)
- Sightseeing

Thu 30th July - Sat 1st August 2015
Berlin



Berlin is the capital of Germany and one of the most exciting cities in Europe. We will visit the most well-known of Berlin's many attractions. AEG, SIEMENS and other companies began their activities as pioneers of industrialisation more than 100 years ago.

Innovative hybrid electric and mechatronic systems are the main subjects of the Summer School in Berlin.

The programme* in Berlin is planned to be:

- Theory of Hybrid Electric Vehicle Concepts
- Hybrid Operating Strategy with Practical Exercise
- Micro Hybrid Systems with Practical Exercise

Leisure programme* is planned.

HAWtech

German Alliance for Applied Sciences



HAWtech

German Alliance for Applied Sciences



HAWtech

German Alliance for Applied Sciences

